



IS 8-16 X - IS 12 VX

ensacadoras manuais

- Corpo e cilindro em aço inox AISI 304.
- Robusto cilindro riscado e com dupla selagem do fundo.
- Pistão em nylon alimentar com válvula respiradora.
- Caixa de engrenagens em aço zincado.
- Engrenagens em aço temperado e retificado.
- Deslizamento das engrenagens sobre 4 rolamentos herméticos.
- Sistema de redução de velocidade dupla.
- fornecidos: 3 funis em nylon alimentar branco e braçadeira de fixação



IS 8-16 X



IS 12 XV

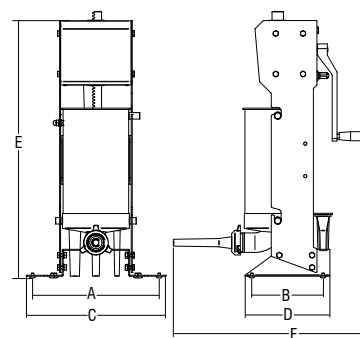
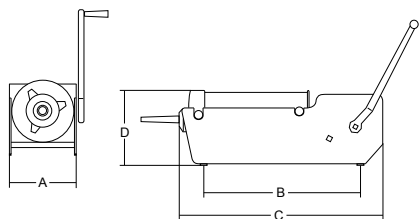

	lt	mm	ø mm	mm	ø mm	mm	mm	mm	mm	mm	mm	kg	mm	kg
IS 8 X	8	370	165	420	10-18-25	200	430	660	220	-	-	19	730x260x250	20
IS 16 X	16	500	200	560	10-18-25	240	575	820	250	-	-	23,5	890x310x280	24,5
IS 12 XV	12	380	200	420	10-18-25	400	190	435	250	794	602	24	890x310x280	26



Suporte dos funis

Tombamento cilindro



IS 12 XV

Excepcional facilidade de limpeza



IS 8-16 X